

These coolers are ideal for the following applications:

- to cool smaller volumes down to -90°C,
- to remove reaction heat or
- to replace tap water cooling

The lowest reachable temperature depends upon:

- the quantity of liquid
- the type of liquid and its viscosity
- the bath insulation

Flow-Through Cooler HAAKE DK15

This cooler is used in the liquid circuit of a heating circulator. Heat is removed from the liquid as it flows through the cooler.

Immersion Coolers HAAKE EK20/EK30

Used together with the open-bath circulators, these coolers provide an alternative to tap water cooling. The lowest attainable temperature and the cooling down times are illustrated in the diagrams.

The EK20 is designed for baths with a 15 cm depth and the EK30 for baths with a depth of at least 20 cm.

Vessels can of othersizes also be cooled. End temperatures of -25°C resp. -30°C can be reached in a 5 l Dewar vessel.

Immersion Cooler HAAKE EK45

This multi-purpose cooler has its own controller with digital temperature display, reaching temperatures down to -45°C in a 5 l Dewar vessel. The controller enables temperature accuracy of approx. 1°C to 2°C. Improvement is possible using a stirrer.

Immersion Cooler HAAKE EK90

This unit is designed for working temperatures down to -90°C. The cooling coil is flexible and can therefore be adapted to suit virtually any bath shape. The minimum diameter of the vessel to be cooled is 110 mm.

Comes with

EK45 and EK90:

Electronic controller

and Pt100 sensor (Ø 6 mm, 50 mm long, cabel 2.5 m long).

Optional accessories

Order-No.

Trolley with castors

for EK90

333-0508

Holder to fix a cooler EK20, EK30 or EK45 onto a wall with a thickness up to 25 mm

333-0602

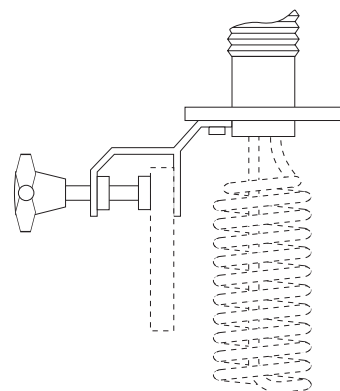

Technical specification acc. to DIN 12876		DK15	EK20	EK30	EK45	EK90
Working temperature range	°C	-15..150	-25..150	-30..150	-45..40	-90..40
Cooling at	20°C	300	300	400	350	300
	at -10°C	150	150	250	250	280
	at -40°C	–	–	–	50	170
	at -60°C	–	–	–	–	100
Hose length	cm	–	150	150	150	150
Cooling coil dimensions (Ø x L)	mm	–	81x145	81x195	81x195	13x900
Smallest bending radius	mm	–	–	–	–	40
Connecting nozzles for hoses	mm Ø	12 and 8	–	–	–	–
Overall dimensions: WxLxH	cm	23x46x38	23x46x38	23x46x38	23x46x38	38x46x49
Net weight	kg	22	22	23	30	60
Total wattage	VA	160	160	270	300	750
Order-No. for 230V / 50..60Hz for 115V / 60Hz		106-1151	322-1201	323-1301	328-1451	329-1901
		106-1152	322-1202	323-1302	328-1452	–

